

OWNER'S MANUAL/INSTALLATION INSTRUCTIONS

WINEGARD® RV ANTENNA

All Sensor® Models

MADE IN U.S.A.

STEP 1: Choose location for antenna that will allow it to rest in travel position with antenna pointing toward rear of vehicle and raise and rotate without interfering with other roof-mounted equipment. Make sure inside ceiling area is clear where ceiling plate will mount.

NOTE: Figure 1 shows minimum distance mount should be located from edge of vehicle roof. We recommend you check with your dealer or the manufacturer to see what provisions have been made in the roof for mounting the antenna. A reinforced area in the roof as well as pre-wired download may be available. For sloped/round roofs, use Winegard Model RW-1000, roof wedge, to level installation.

STEP 2: Locate template and drill 1-3/4" hole through roof and ceiling of vehicle. Take care to avoid damage to wiring which may run between roof and ceiling.

STEP 3: Drill 1/2" hole for cable entry through roof of vehicle only. DO NOT DRILL THROUGH CEILING. Route download cable through ceiling and wall to power supply location.

STEP 4: The mount is designed to fit roofs from 1" to 4-3/4" thick. As supplied, the mount will fit a roof 4-3/4" thick. If roof is less than 4-3/4" thick, cut elevating shaft and directional handle to size, per table below. If roof is more than 4-3/4" thick (max. 6"), a directional handle extension is needed. Order Model EK-1036, Directional Handle Extension.

* The handle and extension should be glued together *after checking that you have the correct length*. The handle will not work properly if it is not glued together! (PVC glue is recommended; for your safety, use according to manufacturer's directions.)

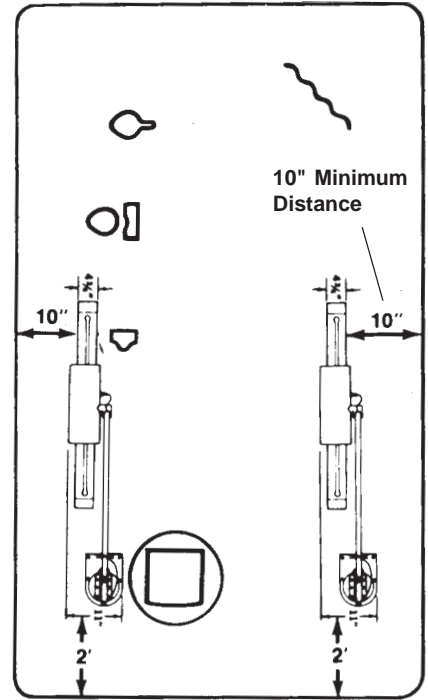

FRONT OF VEHICLE
FIGURE 1 ↓

ROOF THICKNESS	ELEVATING SHAFT LENGTH	W/RW-1000	DIRECTIONAL HANDLE LENGTH	HANDLE LENGTH	EXTENSION LENGTH
6"	7 3/8"	7 7/8"	5 15/16"	3 11/16"	2 1/4"
5 3/4"	7 1/8"	7 5/8"	5 11/16"	3 7/16"	2 1/4"
5 1/2"	6 7/8"	7 3/8"	5 7/16"	3 3/16"	2 1/4"
5 1/4"	6 5/8"	7 1/8"	5 3/16"	2 15/16"	2 1/4"
5"	6 3/8"	6 7/8"	4 15/16"	2 11/16"	2 1/4"
4 3/4"	6 1/8"	6 5/8"	4 11/16"	2 7/16"	2 1/4"
4 1/2"	5 7/8"	6 3/8"	4 7/16"	4 7/16"	Not Used
4 1/4"	5 5/8"	6 1/8"	4 3/16"	4 3/16"	Not Used
4"	5 3/8"	5 7/8"	3 15/16"	3 15/16"	Not Used
3 3/4"	5 1/8"	5 5/8"	3 11/16"	3 11/16"	Not Used
3 1/2"	4 7/8"	5 3/8"	3 7/16"	3 7/16"	Not Used
3 1/4"	4 5/8"	5 1/8"	3 3/16"	3 3/16"	Not Used
3"	4 3/8"	4 7/8"	2 15/16"	2 15/16"	Not Used
2 3/4"	4 1/8"	4 5/8"	2 11/16"	2 11/16"	Not Used
2 1/2"	3 7/8"	4 3/8"	2 7/16"	2 7/16"	Not Used
2 1/4"	3 5/8"	4 1/8"	2 3/16"	2 3/16"	Not Used
2"	3 3/8"	3 7/8"	1 15/16"	1 15/16"	Not Used
1 3/4"	3 1/8"	3 5/8"	1 11/16"	1 11/16"	Not Used
1 1/2"	2 7/8"	3 3/8"	1 7/16"	1 7/16"	Not Used
1 1/4"	2 5/8"	3 1/8"	1 3/16"	1 3/16"	Not Used
1" min.	2 3/8"	2 7/8"	15/16"	15/16"	Not Used

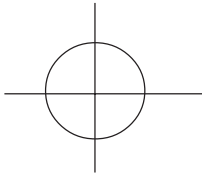

(Template)

1/2" DIA.

**NOTE: DO NOT DRILL
THROUGH CEILING IN
EXPOSED AREA.**

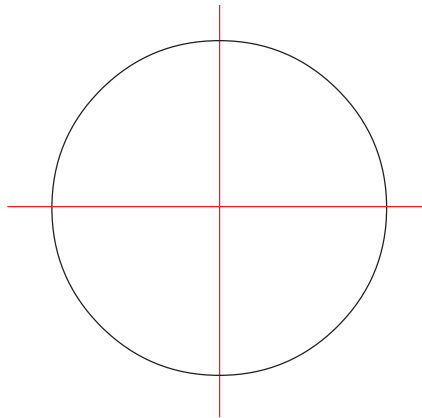

1-3/4" DIA.
DRILL COMPLETELY
THROUGH CEILING



TOWARD FRONT
OF VEHICLE

1/8" DRILL BIT
10 HOLES. DO NOT
DRILL THROUGH CEILING.

MINIMUM OF 5 FT.
CLEAR SPACE



ALL MODELS

STEP 5: Attach antenna head to lift tubes with two (2) steel pins as shown in Figure 2. Align holes in leveling bracket on back of antenna head with holes in lift tubes, insert pins and secure in place with (2) E-clips. **Use pliers and get a firm grip on E-clips.** Fit clips into groove on pins and snap into place.

STEP 6: Attach coax connector to jack on back of antenna head, slide weather boot into place over boot collar as shown in Figure 3.

STEP 7: Mount antenna and lift on roof in travel position. Apply a liberal amount of approved nonhardening sealing compound on bottom of base plate and roof area around hole. See Figure 4. Secure base plate with screws provided. Apply sealing compound over mounting screws. See Figure 4.

STEP 8: Lay ceiling plate on top of **directional handle** with pointers aligned and slide assembly over **rotating base shaft** in ceiling. Make pilot holes in ceiling. **Mount ceiling plate with directional handle in place** with screws provided. See Figure 5.

STEP 9: Assemble directional handle, spring, nylon bearing, directional handle decal and elevating crank as shown in exploded view in Figure 5. Remove backing from crank cover decal and press firmly inside directional handle. Slide all parts over elevating shaft and install elevating crank so set screw is on one of the six flat sides of elevating shaft before tightening screw.

WARNING: Once set screw touches shaft, tighten only 1/4 turn more. Set screw simply holds elevating crank on. **DO NOT OVERTIGHTEN!**

NON-AMPLIFIED MODELS ONLY

STEP 10: Run download to TV set location and make connection to antenna terminals of TV set.

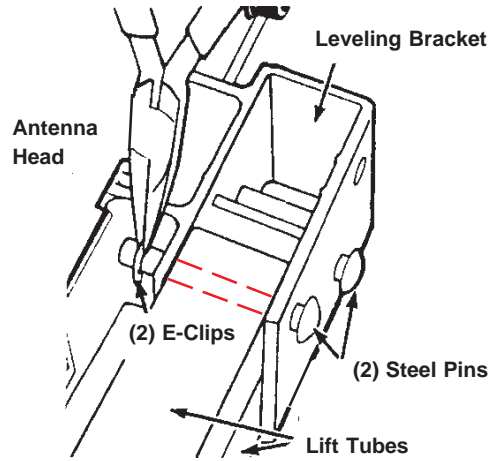

FIGURE 2

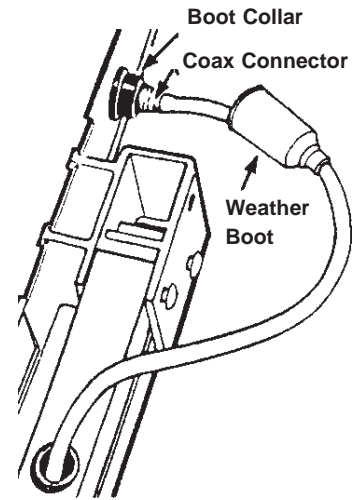

FIGURE 3

NOTE: Apply non-hardening sealing compound between Base Plate and roof of vehicle. Check manufacturer's information for compatibility with your roof material

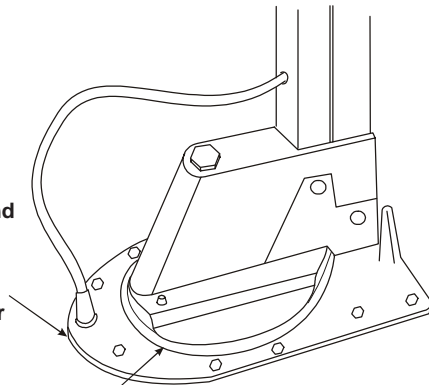

FIGURE 4

CAUTION: Do not get sealing compound on bearing surface between base plate and Rotating Gear Housing. Do not paint top of Base Plate or around Rotating Gear Housing.

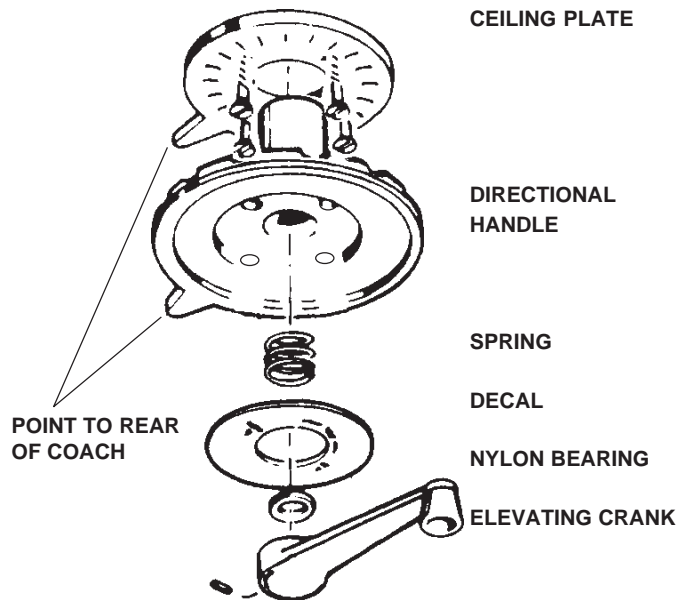

FIGURE 5

AMPLIFIED MODELS ONLY

STEP 10: Select location for wall plate. Run two coax cables (three if set 2 jack is going to be used) (RG-59 type) between locations and install connectors on each end. **Mark cables so "cable input", "TV output" "Set 2" may be identified.** Antenna downlead and +12 VDC will also be needed at inside wall plate/power supply location.

STEP 11: The wall plate/power supply assembly may be flush mounted in most standard electrical boxes. To flush mount cut a hole in wall to fit the box. Run 2 #12 wires between wall plate/power supply and +12 VDC source and route downlead cable to this location.

CAUTION

THE POWER SUPPLY SHOULD BE TURNED OFF WHEN CONNECTING CABLES/WIRES TO POWER SUPPLY. SEE FIGURE 10.

STEP 12: Make 12 volt connection to wall plate/power supply Figure 6. Install terminals on wires from +12 VDC source as shown in Figure 7. Crimp terminals with Craftsman type 4 crimping tool or equivalent. See Figure 8. Push wires onto tabs on terminal board as shown in Figure 6. If in doubt as to the polarity of the wires, connect them temporarily to tabs on circuit board and press ON switch on front of wall plate; if light comes on polarity is correct. See Figure 10.

STEP 13: Install connectors on downlead, set 2 and cable input cables as shown on page 6. Attach downlead cable to jack on wall plate/power supply marked antenna as shown in Figure 9. Attach cable going to set 2 outlet to jack on power supply marked SET 2. Attach cable coming from cable input to jack on power supply marked CABLE.

STEP 14: Mount power supply in wall with screws provided and attach TV set cable to jack on front of power supply/wall plate. Press ON switch on front of wall plate and check that light is on. See Figure 10.

CHECKING OPERATION OF POWER SUPPLY

1. Tune TV receiver to nearest station and rotate antenna for best picture and sound.
2. Press OFF switch on power supply. Picture on TV should be considerably degraded with power off.
3. **This unit is equipped with a polyswitch**, (current limiting device), which will shut down +12 VDC if there is a direct short between antenna and power supply. Red indicator light will not light. Once short is eliminated, device will reset itself.

ADDING OPTIONAL AMPLIFIED WALLPLATE TO NON-AMPLIFIED RV/TV INSTALLATION

The RA-7596 solid state TV signal amplifier works with any non-amplified RV/TV antenna. Improves picture quality. Uses +12 VDC. Has on/off switch, indicator light, set 2 output, cable input and +12 VDC receptacle.

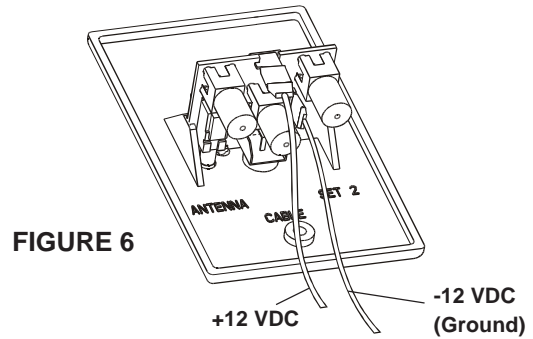

FIGURE 6

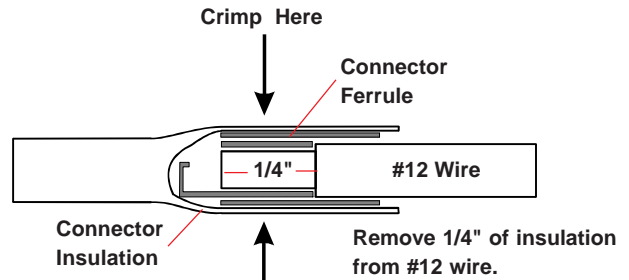

FIGURE 7

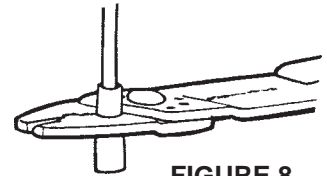

FIGURE 8

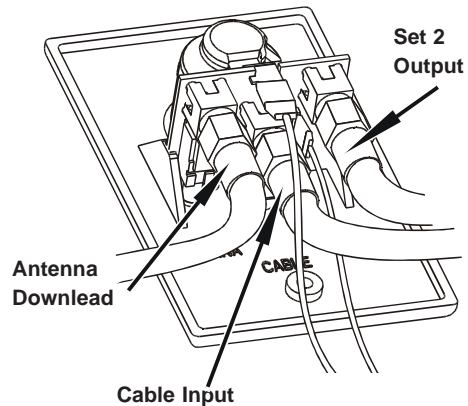

FIGURE 9

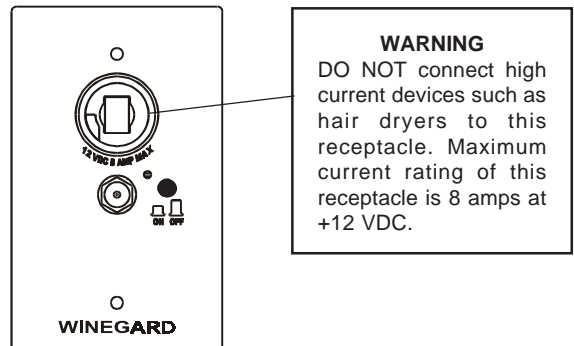

FIGURE 10

OPERATING AND MAINTENANCE INSTRUCTIONS FOR YOUR WINEGARD RV/TV ANTENNA

RAISING ANTENNA TO OPERATING POSITION



Turn elevating crank (clockwise) in "UP" direction about 13 turns or until some resistance to turning is noted.

AMPLIFIED MODELS ONLY

Turn power supply ON to use either front or rear TV outlet. Neither outlet will work unless power supply switch is ON.

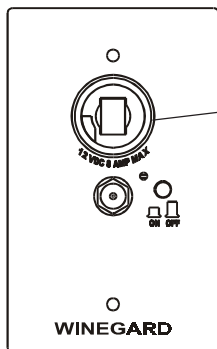

WARNING
DO NOT connect high current devices such as hair dryers to this receptacle. Maximum current rating of this receptacle is 8 amps at +12 VDC.

ROTATING ANTENNA FOR BEST PICTURE



Make sure antenna is in "UP" position. Pull down on both hands until it disengages ceiling plate and rotate for best picture.

LOWERING ANTENNA TO TRAVEL POSITION

Rotate antenna until pointer on directional handle aligns with pointer on ceiling plate. Turn elevating crank (counter clockwise) in "DOWN" direction about 13 turns or until resistance is noted. Antenna is now locked in travel position.

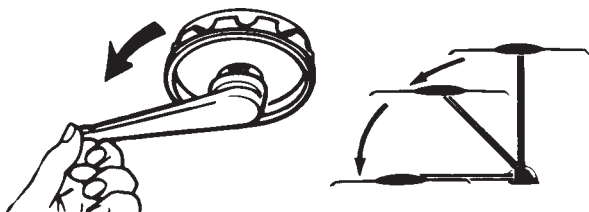

IMPORTANT: Under no conditions lower antenna in any position except travel position.

LUBRICATION

STEP 1: To lubricate the elevating gear, apply a liberal amount of silicone spray lubricant to the elevating gear with the lift in the down position (see illustration below), then run the lift up and down a few times to distribute the lubricant over gears.

STEP 2: Twice yearly or in the event that rotating the antenna becomes difficult, normal operation can be restored by lubricating the bearing surface between the rotating gear housing and the base plate. Any **silicone lubricant spray** may be used. Elevate antenna and remove set screw or plastic plug from rotating gear housing as shown. Spray lubricant into hole and around edges of gear housing. Rotate gear housing until lubricant coats bearing surfaces and antenna rotates freely.

Lubricate Here

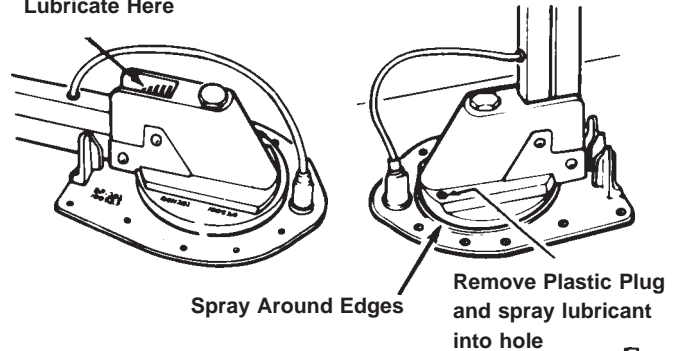

LUBRICATING RUBBER QUAD RING

Lubricate rubber quad ring on elevating shaft which is below worm gear with silicone spray lubricant at least twice yearly. This will keep quad ring from becoming brittle which could result in leaks down elevating shaft. Refer to page 8 for removing worm gear assembly. Item #6 on parts explosion.

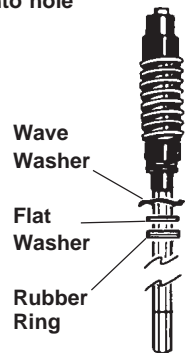

DO'S

1. Do check parking location for obstructions before raising antenna.
2. Do carefully raise, lower and rotate - if difficult, check for cause.
3. Do rotate slowly when selecting station and check fine tuning on TV set to make sure it is properly adjusted.
4. Do lower antenna before moving vehicle.

DON'T'S

1. Don't force elevating crank up or down, check for cause of trouble.
2. Don't rotate directional handle hard against stops.
3. Don't travel with lift in up position.
4. Don't leave lift part way up or down.
5. Don't apply sealing compound or paint over top of base plate or anywhere on lift.

WHAT TO DO WHEN YOUR RV/TV ANTENNA IS NOT WORKING PROPERLY

INSTALLING FC-5900 CONNECTORS ON COAX CABLE

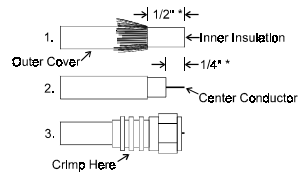

Step 1. Strip outer cover back 1/2" from end of cable. Fray braid back as far as outer cover will allow.

Step 2. Trim braid close to outer cover and remove 1/4" of inner insulation being careful not to nick center conductor. Make sure no foil or braid can touch center conductor.

Step 3. Slide connector tip between braid and inner insulation (braid and foil, on foil shield cable) and push connector on cable as far as it will go. Crimp built-in ferrule with proper crimping tool. Hex connector requires hex crimping tool. Do Not crush cable out-of-round.

* If installing in very hot weather, increase these dimensions 1/8".

WARNING

DO NOT INSTALL COUPLERS, SPLITTERS, ETC. BETWEEN THE POWER SUPPLY AND THE ANTENNA. INSTALLATION OF ANY ITEM ON THE DOWNLEAD MAY CAUSE A SHORT IN THE SYSTEM. THE DOWNLEAD SUPPLIES +12 VDC TO THE PREAMP IN THE ANTENNA.

HOW YOUR SYSTEM WORKS

Turning power supply on sends +12 VDC up cable to antenna. Voltage energizes transistors on amplifier in antenna head. TV signal comes back down cable to outlets.

TO TEST SYSTEM

1. Make sure TV set is working properly.
2. Switch power supply ON and OFF to see if there is a difference in the picture quality while watching TV. If NO difference, use following steps.

CAUTION

The power supply should be turned OFF when connecting/disconnecting cables to power supply and antenna, but should be turned ON when testing for voltage.

3. Disconnect cable from antenna and check for +12 VDC at Test Point #1. If there is +12 VDC, the power supply is OK and the antenna needs to be replaced.
4. If there is NO +12 VDC at Test Point #1 reconnect cable to antenna. Remove power supply from wall and visually inspect for burnt/broken parts. If there are ANY broken or burnt parts replace power supply.
5. Disconnect cable from antenna jack on power supply. Check for +12 VDC Test Point 2. If +12 VDC is present, there is a problem in the cable connecting the power supply to the antenna. Repair/replace cable.

NOTE

Power supplies manufactured after Oct., 1991 have a polyswitch. The polyswitch shuts the power supply off if a short in the cable is detected. The polyswitch will reset itself in approximately two minutes after the short in the cable is removed.

6. If +12 VDC is not present at Test Point # 2, check that the green indicator light is ON. If not, check the polarity of the red/white wires and check the +12 VDC source. If there is still no +12 VDC replace power supply.

HOW YOUR SYSTEM WORKS

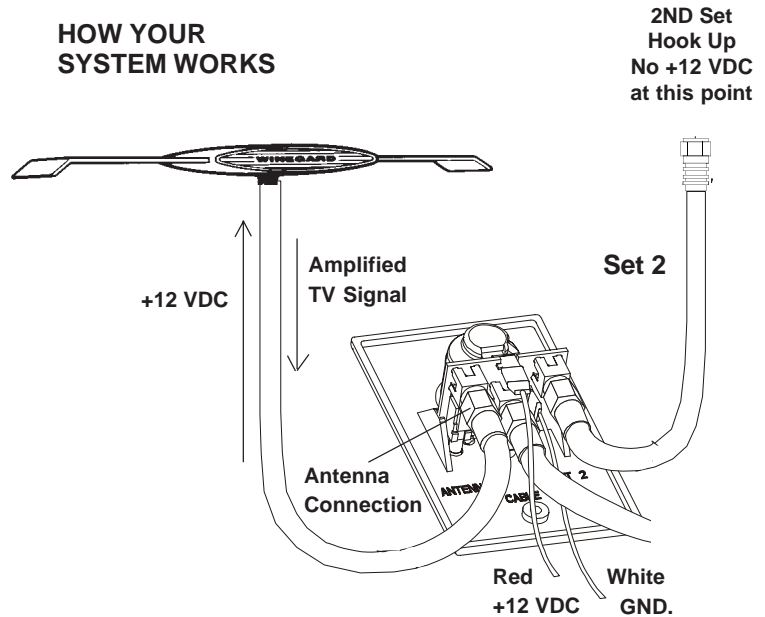

TO TEST SYSTEM

TEST POINT #1
+12 VDC at Antenna

2ND Set
No +12 VDC
at this point

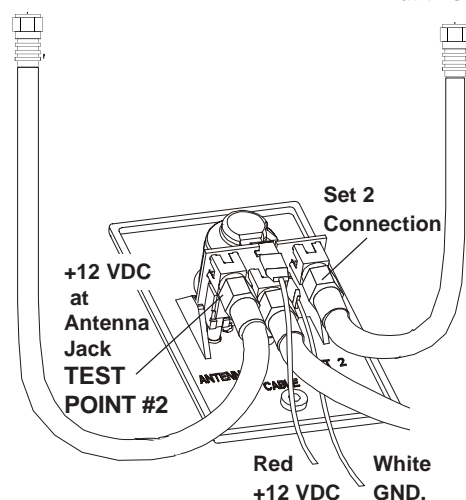

ORDERING REPAIR PARTS

Repair parts are available at many RV dealers and/or service centers throughout the country. If you don't have a dealer/service center near you, call Winegard Company at 1-800-288-8094. Parts are available **only** in the packages shown here. **Order by the Model No. of the package needed.** Example: To order the elevating gear, order RP-3000. Tax, shipping and handling additional.

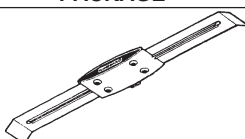
PACKAGE	MODEL NO.	PRICE
1 	RV2001A	78.22
	Amplified	
	Antenna Head	
	75 ohm	

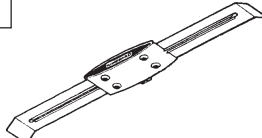
1 	2120430	39.75
	Non-Amplified	
	Antenna Head	
	75 ohm	

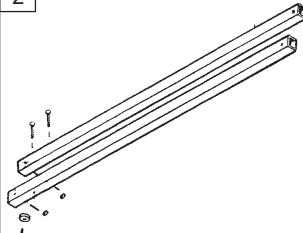
2 	RP-2900	15.60
	2 Elevator Tubes	
	2 Grommets	
	4 Pins	
	4 Retaining Rings	
	Rubber Bumper	
	Self Drilling Screw	

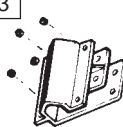
FOR MODELS MADE BEFORE 1990 3 	RP-2000	5.55
	Leveling Mount	
	4 Spacers	
	2 Pins	
	2 Rings	

4 	RP-0154	1.50
	Boot	

5 	RP-3000	3.75
	Elevating Gear	

6 	RP-4000	10.95
	Worm Gear & 12.25" Hex Elevating Shaft Assembly w/ Wave Washer Flat Washer "O" Ring Worm Gear Nut	

14 	RW-1000	4.95
	Roof Wedge	

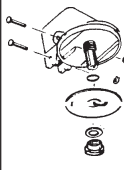
PACKAGE	MODEL NO.	PRICE
7 	RP-2049	24.90
	Gear Housing	
	2 Pins	
	Bearing	
	Nut *	
	Bearing	
	O-Ring Seal Retaining Ring	

* Remove/tighten with 15/16" 12 socket.		
8 	RP-3523	13.40
	Base Plate	
	10 Screws	
	Rubber Boot	

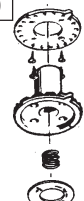
9 	RP-6200	4.85
	IVORY	
	Directional Handle	
	Ceiling Plate	
	4 Screws	
	Spring	
	Decal	

9 	RP-6300	4.85
	WHITE	
	Directional Handle	
	Ceiling Plate	
	4 Screws	
	Spring	
	Decal	

10 	RP-6822	1.40
	Spring	

11 	RP-2658	1.40
	Nylon Bearing	

AFTER 1989 12 	RP-5895	5.30
	IVORY	
	Crank, Set Screw, Hex Shaft	

NEW 1993 12 	RP-6795	5.30
	WHITE	
	Crank, Set Screw, Hex Shaft	

FITS ALL 12 	RP-5000	5.30
	IVORY	
	Crank, Set Screw, Round Shaft	

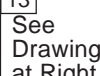
FITS ALL 13 	SA-1001 IVORY	71.50
	Preassembled Elev. Shaft, Gear Hsg., Base Plate	

15 	EK-1036	2.15
	Directional Handle Extension	

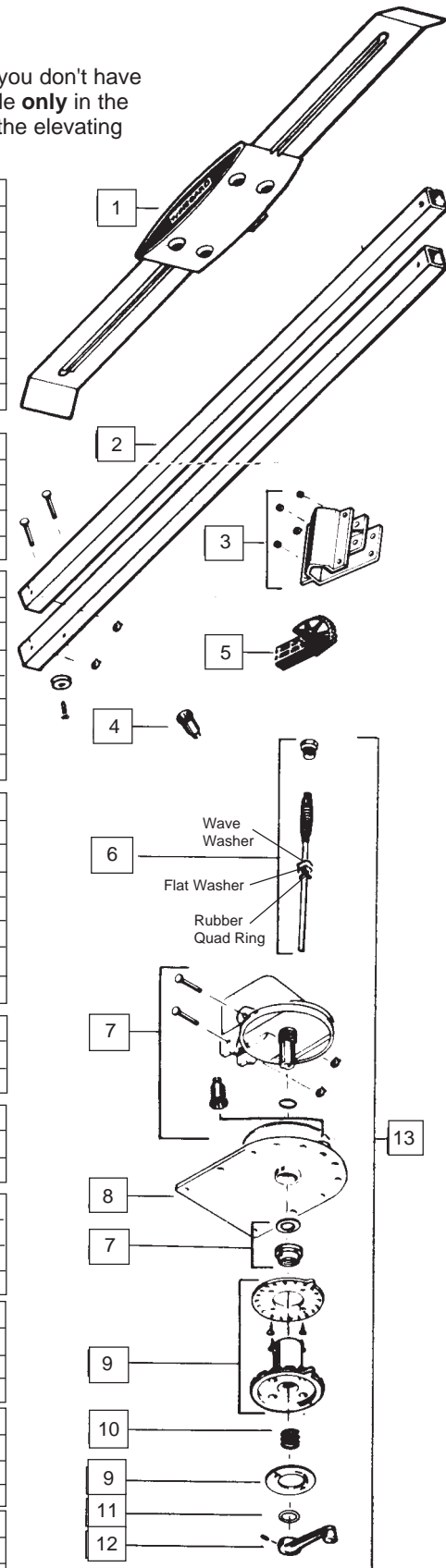

**** Use 3/32 Allen Wrench for set screw**

For elevating shaft and worm gear assembly replacement procedure, see page 8.

SENSAR ANTENNA/LIFT TWO YEAR LIMITED WARRANTY

Winegard Company warrants this Winegard product against any defects in materials or workmanship within two (2) years from date of purchase. No warranty claim will be honored unless at the time the claim is made, you present proof of purchase to an authorized Winegard dealer (if unknown, please contact Winegard Company, 3000 Kirkwood Street, Burlington, Iowa 52601-2000, telephone 319-754-0600).

Winegard Company (at its option) will either repair or replace the defective product at no charge to you. This warranty covers parts, but does not cover any costs incurred in removal, shipping or reinstallation of the product. This limited warranty does not apply if the product is damaged, deteriorates, malfunctions or fails from: misuse, improper installation, abuse, neglect, accident, tampering, modification of the product as originally manufactured by Winegard, usage not in accordance with product instructions or acts of nature such as damage caused by wind, lightning, ice or corrosive environments such as salt spray and acid rain. (SENSAR®) This limited warranty does not apply if any other antenna is mounted to the SENSAR lift, if any other lift is mounted to the SENSAR antenna, or if the SENSAR antenna receiving elements are modified in any manner whatsoever.

The Two Year Warranty is provided on the condition that the equipment is properly delivered with all handling and freight charges prepaid to your Winegard dealer for repair or return to our factory at the above address. Winegard dealers will arrange for the replacement or repair and return to you, without charge, the product which failed due to defective material or workmanship.

WINEGARD COMPANY WILL NOT ASSUME ANY LIABILITIES FOR ANY OTHER WARRANTIES, EXPRESS OR IMPLIED, MADE BY ANY OTHER PERSON.

ALL OTHER WARRANTIES WHETHER EXPRESS, IMPLIED OR STATUTORY INCLUDING WARRANTIES OF FITNESS FOR A PARTICULAR PURPOSE AND MERCHANTABILITY ARE LIMITED TO THE TWO YEAR PERIOD OF THIS WRITTEN WARRANTY.

The foregoing shall be the sole and exclusive remedy of any person whether in contract, tort or otherwise, and Winegard shall not be liable for incidental or consequential damage or commercial loss, or from any other loss or damage except as set forth above.

Some states do not allow limitations on how long an implied warranty lasts, or the exclusion of limitation of incidental or consequential damages, so the above limitations or exclusions may not apply to you.

This warranty gives you specific legal rights and you may also have other rights which vary from state to state.

ELEVATING SHAFT & WORM GEAR ASSEMBLY REPLACEMENT PROCEDURE

NOTE: It is not necessary to remove rotating gear housing from base plate or remove antenna from roof to replace the shaft & worm gear assembly . **Step 1:** Lower antenna to travel position. Loosen set screw on elevating crank , remove crank, spring , directional handle.

Step 2: Remove top retaining ring from top pin holding **top** elevating tube in rotating gear housing and remove pin. **Step 3:** Remove plastic plug from top of rotating gear housing, disengage elevating gear, remove elevating shaft assembly . **Step 4:** Lubricate worm gear assembly on new elevating shaft assembly with spray silicone lubricant, **make sure wave washer, flat washer and quad ring are on lower bearing** and insert assembly in housing. **Step 5:** Reinstall plastic plug in top of housing. Gears will mesh automatically once elevating crank is turned. **Step 6:** Replace directional handle, spring and elevating crank. Make sure set screw contacts flat surface on shaft before tightening.

PARTIAL RV DISTRIBUTOR LIST

Carefree Distributing Inc.	3945 E. Main Street	Mesa, AZ 85205	602-830-3220	AZ
Coast Dist. of Gilbert	1400 N. Fiesta Blvd.	Gilbert, AZ 85234	800-495-5858	AZ
Coast Dist. of Corona	231 N. Sherman Ave.	Corona, CA 91720	800-495-5858	CA
Coast Dist., San Jose	1705 Junction Court,	San Jose, CA 95112	800-495-5858	CA
StagParkway, Inc.	1445 E. Riverview Dr.	San Bernardino, CA 92408	909-796-5998	CA
AAA Trailer Supply	9760 W. Colfax Ave.	Lakewood, CO 80215-3964	303-238-1341	CO
Coast Dist., Colorado	11575 B E 40th Ave.	Denver, CO 80239	800-495-5858	CO
Coast Dist. of Florida	203 A Kelsey Lane	Tampa, FL 33619	800-495-5858	FL
StagParkway-Florida	3601 Parkway Blvd.	Leesburg, FL 32748	904-728-5077	FL
Coast Dist. of Georgia	1795 Continental Way	Atlanta, GA 30316	800-495-5858	GA
StagParkway, Inc.	6105 Duquesne Dr. SW, P.O. Box 43463	Atlanta, GA 30336	770-349-7800	GA
			800-456-7824	
Coast Dist. of Indiana	3002 Coast Court	Elkhart, IN 46514	800-495-5858	IN
Northwest Trailer Parts	1631 W Bristol St., P.O.Box 4204	Elkhart, IN 46514-0204	219-262-3546	IN
StagParkway Inc.	52649 Leer Ct.	Elkhart, IN 46514-0426	219-264-0660	IN
DTI, Indiana	304 N. Main St., P.O. Box 286	Middlebury, IN 46520	219-825-5858	IN
			800-289-0919	
Camping World	P.O. Box 90018	Bowling Green, KY 42102-9018	800-626-5944	KY
StagParkway-Massachu.	418 Boston Turnpike, Route 9	Shrewsbury, MA 01545	508-845-7824	MA
Detroit Detroit Hitch Co.	651 Rochester Road	Clawson, MI 48017	313-583-4112	MI
Bell Industries	500 Hardman Ave., P.O.Box 538	S. St. Paul, MN 55075-0538	612-450-9020	MN
Northern Whse. Supply	1081 Hwy 36 E @ Jct. Hwy 61	St. Paul, MN 55109	612-482-9812	MN
Arrow Distributing Inc.	11819 "I" Street	Omaha, NE 68137	402-330-3322	NE
Coast Dist.	6 Clermont Street	Johnstown, NY 12095	800-495-5858	NY
Arrow Distributing	1612 SE 22nd	Oklahoma City, OK 73129	405-677-7106	OK
Coast Dist. of Portland	7914 SE 82nd	Portland, OR 97266	800-495-5858	OR
Northwest Trailer Parts	2705 NE Argyle St., P.O.Box 11007	Portland, OR 97211	503-288-7431	OR
Coast RV of Pennsylvania	175 Greenfield Road	Lancaster, PA 17601-5882	800-495-5858	PA
Carefree of Philadelphia	1243 W. Baltimore Park	Media (Lima), PA 19063	215-565-1850	PA
Coast Dist. of Ft. Worth	7133 Burns Street	Ft. Worth, TX 76118	800-495-5858	TX
Coast Dist. of San Antonio	4706 Macro Drive	San Antonio, TX 78218	800-495-5858	TX
StagParkway Inc.	709 109th Street	Arlington, TX 76011	817-640-3137	TX
StagParkway Inc.	5701 Business Park Dr.	San Antonio, TX 78218	512-661-6745	TX
Coast Dist.	3800 W. 2100 S	Salt Lake City, UT 84120	800-495-5858	UT
AAA Trailer Supply	2323 S. 2300 West	West Valley City, UT 84119	801-972-8007	UT
StagParkway Inc.	Freeport Center Bldg. E-16	Clearfield, UT 84016-0314	800-933-7824	UT
Northwest Trailer Parts	7825 230th SW	Edmonds, WA 98020	800-562-9292	WA
Bell Industries	N117-W18456 Fulton Dr.	Germanatown, WI 53022	414-253-0450	WI
Canada				
Coast-Calgary/Alberta	707 Barlow Trail SE, Bay C	Calgary, AB Canada T2E 8C2	403-273-8385	AB
Coast-Langley	19676 Telegraph Trail #D	Langley, BC Canada V3A 4P8	604-882-3620	BC
Coast-Orillia/Ontario	655 Harvie Settlement Road	Orillia, ON Canada L3V 5H2	705-326-6407	ON
Coast Distr. Syst. /Prov.of Quebec	1545 Marie-Victorian Blvd.	St. Bruno, PQ Canada J3V 6B7	514-866-3613	PQ